



SAFEREX
200 bar systems
300 bar systems



ABOUT VdS

VdS stands for Inspected. Approved. Safe. and is Europe's largest expert organization for fire Protection. It is independent institution which has been ensuring safety and trust in the fields of fire protection and security for many decades.

VdS develops advanced safety concepts for significant industrial and commercial enterprises, leading manufacturers and system businesses as well as specialist firms and independent specialists. Its expert assess more than 21.000 fire protection systems worldwide every year.



TABLE OF COMPONENTS

Components for a complete SAFEREX System	Page 4	
SAFEREX System variants	Page 5	
SAFEREX 200 bar system variants	Page 5	
SAFEREX 300 bar system variants	Page 5	
Extinguishing agent	Page 6	
SAFEREX System agent containers	Page 7	
SAFEREX System discharge valves	Page 9	
SAFEREX System release device	Page 9	
Electromagnetic release devices	Page 10	
Reset tool for electromagnetic release device	Page 10	
Manual release devices	Page 11	
Manual/Pneumatic release device	Page 11	
Pneumatic release device	Page 11	
Constant flow and pressure discharge regulator	Page 12	
Pilot hoses & accessories	Page 12	
Pilot hoses	Page 13	
Adapter for pilot hose	Page 13	
Non-Return valve & Vent valve	Page 13	
Vent valve	Page 13	
Adaptors for pilot hose	Page 13	
Adapter for pilt cylinder valve	Page 14	
Bleed valve	Page 14	
Pressure gauges	Page 14	
Discharge hose & manifolds	Page 15	
Discharge hoses	Page 15	
Check valves	Page 15	
Manifolds	Page 16	
Manifold mounting rails	Page 18	
Accessories for manifolds	Page 18	
Optional components	Page 19	
Nozzels for SAFEREX System	Page 20	
Labels	Page 22	
Software availability	Page 23	
Pneumatic directional valves & control panels	Page 23	
Pneumatic directional valves	Page 23	
Control panels for pneumatic directional valves	Page 24	

SAFEREX System components are approved and certified compliant With recognized international norms. Certification relate to invidual products and are clearly indicated on each respective product page.

SAFEREX Systems certified with system approval by VdS.

Inadditional, all SAFE manufacturing sites comply with ISO 9001 quality standards.

1 According to the Pressure Equipment Directice (2014/68/EU)

2 According to the Transportable Pressure Equipment Directive (2010/35/EU)

3 VdS – approved components

4 Components part of VdS approved system



Components for a complete SAFEREX System

SAFEREX System by SAFE Technology Ltd. is a complete VdS Certified inert gaseous fire protection systems that helps you save time and improves productivity.

SAFE, has done the compatibility, performance testing and certification work for you. The system is ready to configure and requires less space to protect high-value assets in areas difficult to Access. **Safe, effective and VdS-Certified.**

Fire Protection Systems designs and manufactures components need to configure SAFEREX system.



- Components entirely compatible and interchangeable
- Easier and faster installation – No “bad surprises”
- Everything to the same high-specification
- Greater confidence in performance at the critical time
- Full warranty protection
- Simplicity of a single supplier

SAFE makes it easy for system engineers and installers to select a complete VdS-Approved fixed suppression system. Using IG01 – IG100 – IG55 – IG541 with seamless steel high pressure cylinders.



Legent			
1	Agent container	12	Clamp for manifold
2	Clamp for agent container	13	Manifold
3	Agent container wall mounting rail	14	Pneumatic release device
4	Discharge valve	15	Bleed valve
5	Pressure gauge	16	Check valve
6	Electromagnetic release device	17	Nozzle
7	Manual/pneumatic release device	18	Valve protection (safety/shipping) cap
8	Discharge hose	19	Cylinder name plate
9	Pilot hose	20	Adapter for pilot hose
10	Constant flow and pressure discharge regulator	21	Pressure and flow detector switch
11	Manifold mounting rail	22	Pilot line test connection

The **SAFEREX** System helps you to reduce the footprint, installation and service cost by offering you a choice from 80L, 140L and 180L cylinders in 200 bar or 300 bar configurations.

- Less cylinders are needed for your installation due to high filling capacity cylinders.
- The high pressure allows the cylinders to be palced further away from the protection zone.
- Extremely fast discharge of agent within 120 seconds. The fire is out before it has a change spread. Damages and downtime are at an absolute minimum.

The **SAFEREX** System is designed and manufactured by SAFE Technology Ltd. A World leader in reliable control system for pressurized gas applications. The proven technology used in the SAFE VdS-Approved Clean Agent Fre Suppression System has been instalted in thousands of instalations worldwide.

For maximum ease and certain of performance, specify SAFE Technology Ltd. for your entire system.

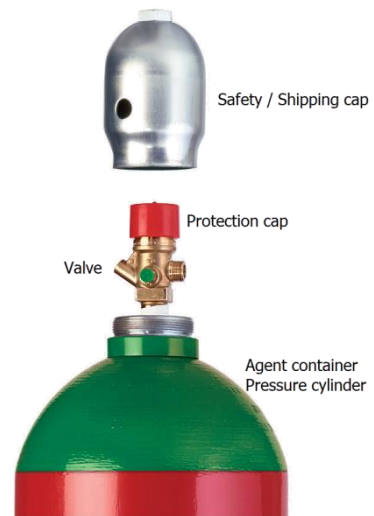

SAFEREX System 200 bar variants

Agent containers with SRX 4000322 series valve assembly	80 l. 200 bar	140 l. 200 bar	180 l. 200 bar
Article number (empty)	SRX 2108200	SRX 2114200	SRX 2118200
Article number (filled IG01)	SRX 2108201	SRX 2114201	SRX 2118201
Article number (filled IG100)	SRX 2108210	SRX 2114210	SRX 2118210
Article number (filled IG55)	SRX 2108255	SRX 2114255	SRX 2118255
Article number (filled IG541)	SRX 2108256	SRX 2114256	SRX 2118256



A complete agent container/valve assembly

- Agent containers for 200/300 bar working pressure SRX 400320 series valves
- VdS approved
- Steel valve protection cap included.

SAFEREX System 300 bar variants

Agent containers with SRX 4000323 series valve assembly	80 l. 300 bar	140 l. 300 bar	180 l. 300 bar
Article number (empty)	SRX 2108300	SRX 2114300	SRX 2118300
Article number (filled IG01)	SRX 2108301	SRX 2114301	SRX 2118301
Article number (filled IG100)	SRX 2108310	SRX 2114310	SRX 2118310
Article number (filled IG55)	SRX 2108355	SRX 2114355	SRX 2118355
Article number (filled IG541)	SRX 2108356	SRX 2114356	SRX 2118356



Label included for filled agent container only

Extinguishing agent

The SAFEREX System is designed for the use with inert gases:

- IG01 (Argon)
- IG100 (Nitrogen)
- IG55 (Argon and Nitrogen)
- IG541 (Nitrogen, Argon and Carbon dioxide)

As inert gases are derived from gases present in the earth's atmosphere, they exhibit no ozone depletion potential and they do not contribute to global warming.

When an inert gas is discharged into an enclosure, it introduces the proper mixture of gas that will allow persons to breathe in a reduced oxygen atmosphere. The advantages of inert gases are:

- People safe at concentration levels required to suppress fire
- Zero ozone depletion
- Zero global warming potential
- Colourless, odourless
- No residue to clean up after discharge
- No decomposition products
- Electrically non-conductive
- Natural gas present in the atmosphere
- Stored as a gas
- Fogging does not occur when agent is discharged

The extinguishing effect of the SAFEREX System is based on distributing the inert gas into the protected area by total flooding. All gases used in the SAFEREX System are chemically inert. Therefore they have an excellent extinguishing efficiency with fires of class A, B and C. All gases used in the SAFEREX System are suitable for the extinguishing of deep-seated fires.

As inert gases are derived from gases present in the earth's atmosphere, full-scale testing can be performed without concerns about environmental impact.

Whereas the cost of clean up and peripheral damage associated with water, foam and dry chemical agents can exceed the cost of the fire damage itself, clean up costs and down time associated with inert gases are negligible.

Most materials and equipment are totally unaffected by exposure to inert gases. Inert gases are stable, even at high temperatures, and does not decompose when subjected to fire; therefore, it does not cause metals to corrode.

The following table shows the physical properties of inert gas extinguishing agents (SI Units).

	IG01	IG100	IG55	IG541
Chemical formula	Ar	N ₂	N / Ar	N / Ar / CO ₂
Molecular weight	39.9 g/mole	28.0 g/mole	34.0 g/mole	34.0 g/mole
Density at 1.013 bar and 20° C	1,662 kg/m ³	1,165 kg/m ³	1,413 kg/m ³	1,418 kg/m ³
Boiling point at 760 mm Hg	-189.85° C	-195.80° C	-190.10° C	-196.00° C
Boiling point at 1013 bar	-185.90° C	-195.80° C	-196.00° C	-196.00° C
Freezing point	-189.35° c	-195.80° C	-199.70° C	-78.50° C
Critical temperature	-122.30° C	-146.95° C	-134.70° C	N/A
Critical pressure	4903 kPa	3999 kPa	4150 kPa	N/A
NOAEL	43%	43%	43%	43%
LOAEL	52%	52%	52%	52%
Specific heat, vapour at constant sure (1 atm) at 25° C	0.519 kJ/kg	1.04 kJ/kg	0.782 kJ/kg	0.574 kJ/kg
Heat of vaporisation at boiling	163 kJ/kg	199 kJ/kg	181 kJ/kg	220 kJ/kg
Relative dielectirc strength at 1 atm	1.01	1.0	1.01	1.03
Solubility of water in extinguishing agent at 25° C	0.006%	0.0013%	0.006%	0.015%
Ozone depletion potential (ODP)	0	0	0	0
Global warming potetial (GWP)	0	0	0	0

Article	Agents
SRX 0010001	IG01
SRX 0010100	IG100
SRX 0010055	IG55
SRX 0010541	IG541

Extinguishing mechanism

The extinguishing effect of inert gases is achieved by the displacement of atmospheric oxygen. This is called the sticking effect, which occurs when the specific limit value required for combustion is not reached. In most cases, the fire extinguishes as soon as the oxygen level is reduced to 13,8 % by volume. For this purpose, the existing air volume only has to be displaced by about one third, which corresponds to an extinguishing gas concentration of 34 % by volume.

In the case of fuels which require considerably less oxygen to burn, an increase in the extinguishing gas concentration is necessary, for example ethine, carbon monoxide and hydrogen. As the extinguishing gases argon and carbon dioxide are heavier than the ambient air, they penetrate the flooding area particularly quickly and thoroughly.

To improve the extinguishing properties, mixtures of argon, nitrogen and carbon dioxide are also used as extinguishing agents.

NOAEL and LOAEL values are listed in the following table.

Level	Minimum level of oxygen	Equivalent maximum concentration of extinguishing agent (inert gas)
NOAEL	12%-vol	43%-vol
LOAEL	10%-vol	52%-vol

SAFEREX System agent containers

IG01, IG100, IG55 and IG541, when used as extinguishing agents are stored in gaseous state in agent containers. The pressure inside the agent container varies as the ambient temperature changes. In general, the ambient storage temperature for agent container used in total flooding applications is 0 °C to +35 °C.

agent container must be stored and installed vertical in a well ventilated, dry, cool, secure area that is protected from weather conditions and preferably fire-resistant.

Our agent containers are manufactured according to transportation TPED regulations, which specify the material of construction, method of manufacture, testing, and what products they are permitted to be filled with, as well as other details.

Agent containers for SRX 4000322 valve

Article number	SRX 0108027	SRX 0114035	SRX 0118040
Water volume	80 liters	140 liters	180 liters
External diameter	267 mm	348 mm	406 mm
Height	1675 mm	1750 mm	1745 mm
Working pressure	200 bar	200 bar	200 bar
Test pressure	300 bar	300 bar	300 bar
Valve connection	25E	25E	25E
Colour	Red, RAL3000	Red, RAL3000	Red, RAL3000
Material	34CrMo4 steel	34CrMo4 steel	34CrMo4 steel
Valve protection cap	W80 x 11F/1"	W80 x 11F/1"	W80 x 11F/1"
Conformity	TPED	TPED	TPED

Agent containers for SRX 4000323 valve

Article number	SRX 0108028	SRX 0114036	SRX 0118040
Water volume	80 liters	140 liters	180 liters
External diameter	273 mm	356 mm	406 mm
Height	1675 mm	1760 mm	1745 mm
Working pressure	300 bar	300 bar	300 bar
Test pressure	450 bar	450 bar	450 bar
Valve connection	25E	25E	25E
Colour	Red, RAL3000	Red, RAL3000	Red, RAL3000
Material	34CrMo4 steel	34CrMo4 steel	34CrMo4 steel
Valve protection cap	W80 x 11F/1"	W80 x 11F/1"	W80 x 11F/1"
Conformity	TPED	TPED	TPED



Agent container mounting brackets for single row containers

Galvanized steel wall mounting rails and clamps are used to mount the agent containers in a vertical position to the wall.

The cylinder wall mounting rail is available for 1 to 6 agent containers.

Part	Container	80 l. Agent containers		140 l. Agent containers		180 l. Agent containers	
		Article	Lenght	Article	Lenght	Article	Lenght
Agent container wall mounting rail	1	SRX 1227301	420 mm	SRX 1236001	510 mm	SRX 1240001	560 mm
	2	SRX 1227302	720 mm	SRX 1236002	910 mm	SRX 1240002	1020 mm
	3	SRX 1227303	1020 mm	SRX 1236003	1310 mm	SRX 1240003	1480 mm
	4	SRX 1227304	1320 mm	SRX 1236004	1710 mm	SRX 1240004	1940 mm
	5	SRX 1227305	1620 mm	SRX 1236005	2110 mm	SRX 1240005	2400 mm
	6	SRX 1227306	1920 mm	SRX 1236006	2510 mm	SRX 1240006	2860 mm
Clamp for agent container		SRX 1426701	Ø267 mm	SRX 1435001	Ø348 mm	SRX 1439001	Ø390 mm
		SRX 1426801	Ø273 mm	SRX 1436001	Ø356 mm	SRX 1440001	Ø406 mm
End cap		SRX 1290001					

Agent container mounting brackets for double row containers

Galvanised steel wall mounting rails, bolts and nuts are used to mount the agent containers in a vertical position to the wall. The container mounting brackets are available in two sizes for 4 or 6 agent containers.

Part	Cylinder	80 l. Agent containers		140 l. Agent containers		180 l. Agent containers	
		Article	Lenght	Article	Lenght	Article	Lenght
Mounting rail	2 X 2	SRX 1227322	720 mm	SRX 1236022	910 mm	SRX 1240022	1020 mm
	3 X 2	SRX 1227323	1020 mm	SRX 1236023	1310 mm	SRX 1240023	1480 mm
Bolts and nuts kit		SRX 1426807	645 mm	SRX 1436007	825 mm	SRX 1440007	925 mm
End cap		SRX 1290001					



Pilot cylinders (for multi-zone systems)

The pilot cylinder is used for pneumatic actuation of the pipework. It should be equipped with valve SRX 4000322 or SRX 4000325 filled with nitrogen.

Article number of pilot cylinder with SRX 4000322 valve with SRX 4000325 valve	SRX 5009132 SRX 5009142	SRX 5009135 SRX 5009145	SRX 5009137 SRX 5009147
Max. number of alarm device	1	2	3
Cylinder article number	SRX 0100514	SRX 0101014	SRX 0102722
Pilot cylinder water volume	5 liters	10 liters	27 liters
External diameter	140 mm	140 mm	229 mm
Height	435 mm	810 mm	900 mm
Working pressure	200 bar	200 bar	200 bar
Test pressure	300 bar	300 bar	300 bar
Valve connection	25E	25E	25E
Colour	Red, RAL3000	Red, RAL3000	Red, RAL3000
Material	34CrMo4 steel	34CrMo4 steel	34CrMo4 steel
Valve protection cap	W80 x 11F/1"	W80 x 11F/1"	W80 x 11F/1"
Filled Nitrogen	60 bar	60 bar	60 bar
Conformity	TPED	TPED	TPED



Bigger volumes of pilot cylinders as shown in the table above are allowed to use.

SAFEREX System discharge valves

Discharge valves

This valve is used on agent containers and it is operated on the master agent container by an electromagnetic release device in combination with a manual/pneumatic release device or manual release device. On the slave agent containers the valve is operated by the pneumatic release device, which is mounted on the M42 x 1,5 actuator connector of the valve.

The pneumatic release device is connected to the master valve by a pilot hose.

Article number	SRX 4000322	SRX 4000323
Cylinder thread	25E	25E
Valve outlet	W21.8 x 1/14"	W21.8 x 1/14"
Burst disc safety device	270 bar	405 bar
Connection for release device	M42 x 1,5	M42 x 1,5
Pilot connection	G 1/8"	G 1/8"
Pressure gauge connection	M10 x 1	M10 x 1
Working pressure	200 bar at +15°C	300 bar at +15°C
Nominal width	12 mm	12 mm
Temperature range TS	-20°C to +50°C	-20°C to +50°C
Conformity	VdS-G302023	

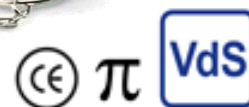

Valve with solenoid actuator for pilot cylinder

SRX 4000325 pilot valve with solenoid actuator used for only SAFEREX System 5L, 10L and 27L pilot cylinders.

Article number	SRX 4000325
Inlet connection	25E
Outlet connection	W21.8 x 1/14"
Burst disk	270 bar
Pressure gauge port	M10 x 1 mm
Voltag.	24 VDC
max. current	0.4 A
Power consumption	9.3W
Material	Brass
Conformity	PED & TPED

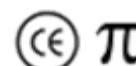

Release devices

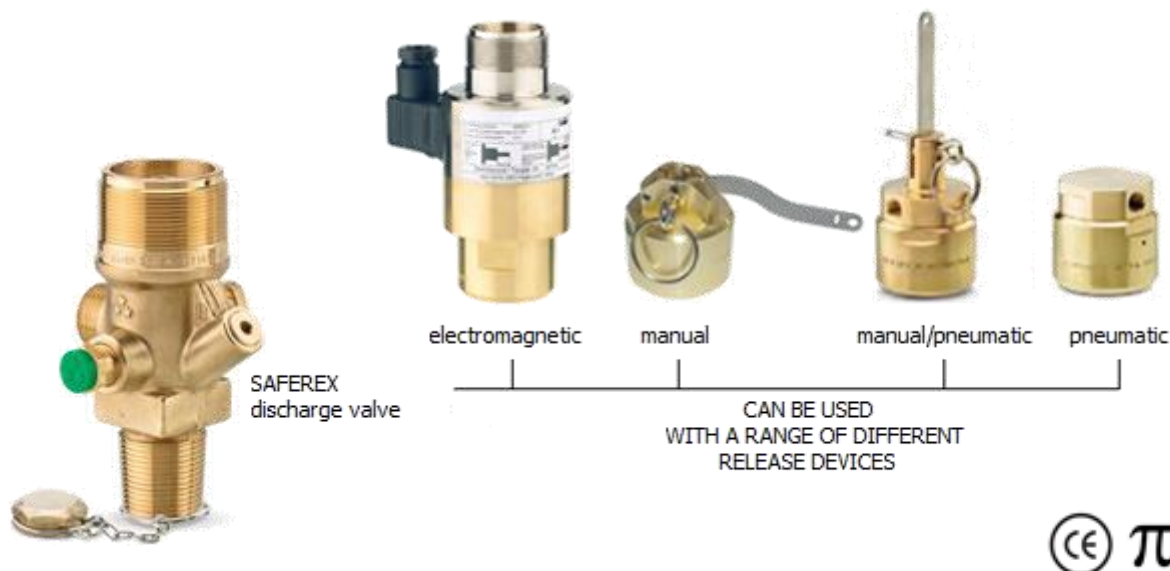

Electromagnetic release device

Device to electrically actuate the release of extinguishing agent.

SRX 4001001 for use with

SRX 4000322
SRX 4000323 valves.

KEY FEATURES

- Most commonly used as a master valve to actuate the system electronically, such as with connection to a smoke or heat detection device
- Electronically actuates the release of extinguishing agent

- 1 Compliant with the Construction Products Regulation (CPR) V3 Oct. 2014
- 2 VdS –approved components
- 4 Components part of VdS – approved system

The electromagnetic release device is used to actuate the SAFEREX System electrically. It is mounted on top of the master valve and is operated by an electrical signal from a fire detection system. In order to actuate the electromagnetic release device a constant DC voltage of 24 V is required.

The electromagnetic release device can be combined with the manual release device, manual/pneumatic release device or the pneumatic release device.

The duration of electrical impulse to actuate must be >5 seconds.

The coil itself has no protective circuit, if necessary this has to be implemented by user with the pilot wiring.

Interchanging polarity of the contacts (+) and (-) does not lead to multifunction of these device or extinguishing system, but ensure to connect the ground connection correctly.

Article number	SRX 4001001 (with diode) SRX 4001002 (without diode) SRX 4001011 (with diode and with blocking device) SRX 4001012 (without diode but with blocking device)
Inlet connection (C)	M42 x 1,5
Nominal voltage (U)	24 V DC ± 10 %
Nominal current (I)	0,5 A ± 10 %
Torque moment	50 +0/-15 Nm
Effective duty cycle (ED)	100 % ED
Electrical connection	DIN 175301-803 A electrical connector
Protection class	IP65
Maximum ambient temperature	+55 °C
Material	Brass and stainless steel Red plastic protection cap
Conformity	VdS-G302023



Reset tool for electromagnetic release device

The reset tool is used to reset the electromagnetic release device pin after a discharge. The reset tool is screwed into the inlet connection of the electromagnetic release device.

Used to reset the electromagnetic actuator piston when putting the system back in active service after system discharge

Article number	SRX 4001091
Connection	M42 x 1,5
Material	Brass



Manual release device

The manual release device allows manual actuation of pilot cylinder SAFEREX System components. This release device is used for manual actuation, which are connected to the pilot agent container.

Manual actuation is accomplished by pulling the hand lever on the manual release device. In the closed position the manual release device is secured with a safety pin. By removing the safety pin, the hand lever can be manually pressed down to actuate the discharge of the extinguishing agent.

Article number	SRX 4001112
Inlet connection	M42 x 1,5
Max.working pressure	300 bar
Torque moment	25Nm ± 2
Ambient temperature	-20 +55 °C
Material	Brass



Manual/Pneumatic release device

The manual/pneumatic release device allows manual or pneumatic actuation of several SAFEREX System components. This release device is used for pneumatic actuation of multiple agent containers in series, which are connected to the master agent container by a pilot hose.

Manual actuation is accomplished by pulling the hand lever on the manual/pneumatic release device.

In the closed position the manual/pneumatic release device is secured with a safety pin.

By removing the safety pin, the hand lever can be manually pressed down to actuate the discharge of the extinguishing agent.

Article number	SRX 4001111
Inlet connection	M42 x 1,5
Maximum working pressure	300 bar
Pilot port	G1/8"
Actuation force / pressure	< 150N / 20 bar
Torque moment	50 ± 0/-15 Nm
Actuation pressure	Pmax 140 bar = 18 bar Pmax 90 bar = 13 bar
Ambient temperature	-20 +55 °C
Material	Brass
Conformity	VdS-G302023



Pneumatic release device

This release device is used for pneumatic actuation of multiple agent containers in series, which are connected to the master valve on the master agent container by a pilot hose. Agent container equipped with the pneumatic release device serve as slave agent containers.

Article number	SRX 4001114	SRX 4001124
Piston	Single	Double
Minimum actuation pressure	21 bar	10 bar
Maximum working pressure	300 bar	
Inlet connection (C)	M42 x 1,5	
Pilot port	G1/8"	
Torque moment	50 + 0/-15 Nm	
Material	Body: brass	
Conformity	VdS-G302023	



Constant flow and pressure discharge regulator

The constant flow and pressure discharge regulator modulates the discharge pressure to a constant pressure, which still delivers the extinguishing agent within 60 seconds or 120 seconds (depending on the kind of Class fire), but with significant performance and cost benefits.

It prevents explosive force of discharge.

Low-pressure manifolds and pipework can be used - that means lower costs.

After a system discharge, no reconditioning of the constant flow and pressure discharge regulator is necessary. Functional tests are possible even while the system is armed.

The constant flow and pressure discharge regulator is screwed with a gasket on the discharge port of the discharge valve.

Article number	SRX 4000328
Inlet connection	W21.8 x 1/14"
Outlet connection	W21.8 x 1/14"
Nominal inlet pressure	200 / 300 bar
Maximum inlet pressure	360 bar
Inlet orifice size	12 mm
Static outlet pressure	60 bar
Material	Brass
Conformity	VdS-G311002



Pilot hoses

Pilot hoses are used to connect several agent container, that are equipped with a valve and the corresponding release device.

The pilot hose is used to set up the pilot line, e.g. to connect several release devices and/or the valve and release device. The pilot hose must only be used in accordance with component approval in SAFEREX Systems.

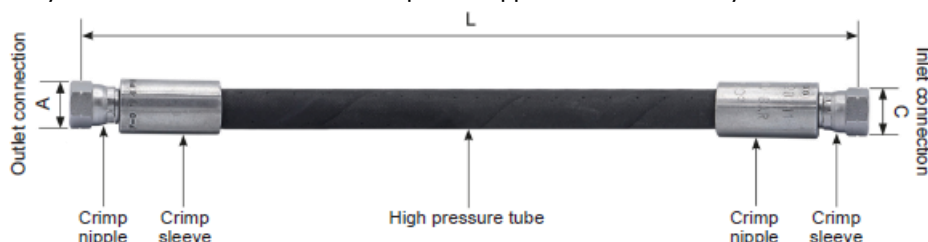

Article number	SRX 4002105	SRX 4002107	SRX 4002110
Lenght	500 mm	700 mm	1000 mm
connectionS	2 X M12 x 1,5		
Bending radius	75 mm		
Nominal diameter	DN6		
Working pressure	400 bar		
Temperature range	-40 °C to +100 °C		
Standard	EN 857 2 SC		
Conformity	VdS-G314018		



Adapter for pilot hose

The adapter is used for the connection of pilot hoses to the manual/pneumatic release device or to the pneumatic release device.

Article number	SRX 4002121
connections	G1/8" / M12 x 1,5
Material	Brass



Each hose requires 2 adapters. Must be ordered separately.

Non-return valve for pilot hose

Non-return valves allow flow in the direction of flow and prevent it in the opposite direction.

For this purpose the component gets assembled, in accordance with the correct flow direction, in the pilot hose line.

Article number	SRX 4002138
Body	Stainless steel; elastomer
Thread (inlet – outlet)	G1/8"
Operating pressure	360 bar
Temperature range	-20 °C up to +50 °C
Installation position	any
Conformity	VdS-G318002

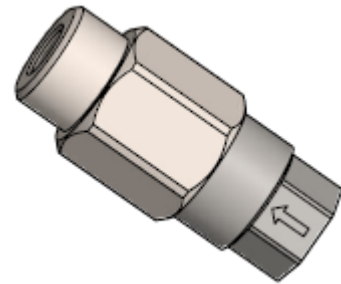

Vent valve for pilot hose

Vent valves are used in fixed installed SAFEREX System for venting pilot line.

Article number	SRX 4002137
Operating pressure	360 bar
Temperature range	-20 °C up to +65 °C
Connections	1 x straight fitting M12 x 1.5 – G1/8" 24° seal cone
Vent holes	∅5mm 8 x 45°
Type of actuation	Manual actuation
Materials	Brass
Conformity	VdS-Test Report

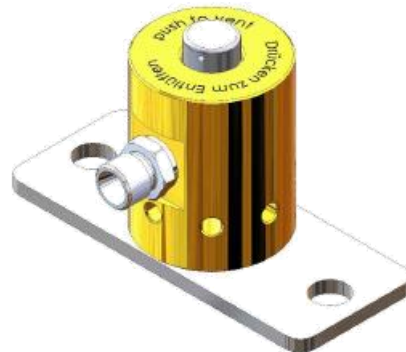

Adaptors for pilot hose

Article number	Description
SRX 4002122	Adapter for pilot hose
SRX 4002126	T – Connector (mid leg)
SRX 4002127	T – Connector (single straight)
SRX 4002128	L – Connector

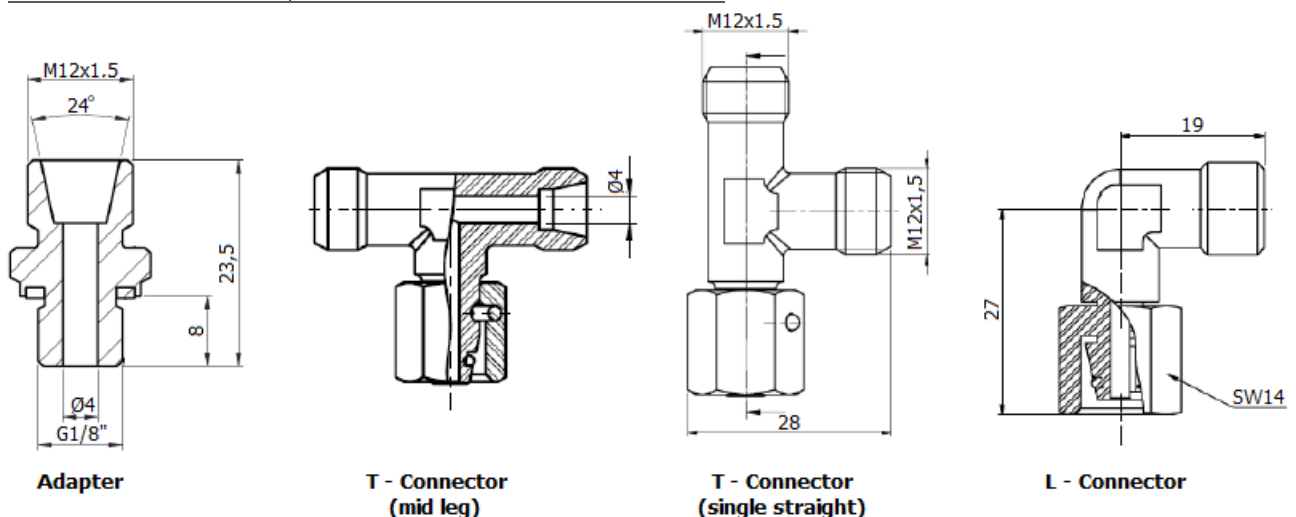

Adapter for pilot cylinder valve

Article SRX 4002139

- To adapt the pilot cylinder to the pilot line
 - Connected to the Pilot Cylinder's outlet port
Therad connection W21,8x1/14"
 - Outlet connection M12x1,5 mm (DKLO 24°) for pilot hose
Straight or with L – Connector

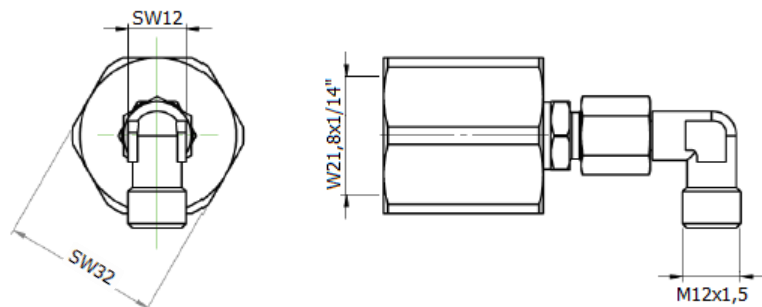

Bleed valve

The bleed valve is a part of the pilot line. The bleed valve must be mounted at the end of each pilot line on the last pneumatic release device. The bleed valve is a safety device, which protects the SAFEREX System against unwanted discharge if a agent container has a leak and the pressure thereby increases in the pilot line. The bleed valve vents the pressure in the pilot line under 0,7 bar and thus prevents an accidental discharge.

Article number	SRX 4002131
Max. working pressure	300 bar at 15° C
Closing pressure	0,7 bar – 1,5 bar
Inlet connection (C)	G1/8"
Conformity	VdS-Test Report 141539-AU01+GLA01-PB01



Pressure gauges

The pressure gauge measures the pressure in the agent container. It is equipped with an integrated pressure switch to supervise the loss of pressure in the agent container.

Each valve must be equipped with a pressure gauge.

The pressure gauge is screwed into the port for optional parts of the valve.

Article number	SRX 4001273	SRX 4001276	SRX 4001274	SRX 4001277
Most suitable for pressure scale	200 bar	300 bar	300 bar	300 bar
Scale	0 – 315 bar	0 – 315 bar	0 – 400 bar	0 – 400 bar
Inlet connection (C)	M10 x 1	M10 x 1	M10 x 1	M10 x 1
Pressure switch	Yes	Yes	Yes	Yes
Switch point	180 bar	180 bar	270 bar	270 bar
Type of switch	(NO)	(NC)	(NO)	(NC)
Conformity	VdS-G309005	VdS-G309005	VdS-G309005	VdS-G309005



Pressure gauges for pilot cylinder

Article number	SRX 4001212	SRX 4001236
Most suitable for pressure scale	100 bar	100 bar
Scale	0 - 100 bar	0 – 100 bar
Valve connection	M10 x 1	M10 x 1
Pressure switch	No	Yes
Switch point	--	45 bar
Type of switch	--	(NC)
Conformity	VdS-G308005	VdS-G309005



Discharge hoses

The discharge hose is used for the connection of the constant flow and pressure discharge regulator to the check valve. The discharge hose provided with one W21.8 x 1/14" nut and one G3/4" nut. The nuts are protected with plastic caps, which must be removed before installation. The W21.8 x 1/14" nut with the inserted gasket is installed on the constant flow and pressure discharge regulator. The G3/4" nut with the inserted gasket is connected to the check valve.

The discharge hose SRX 4002270 is used for 140 l agent containers.

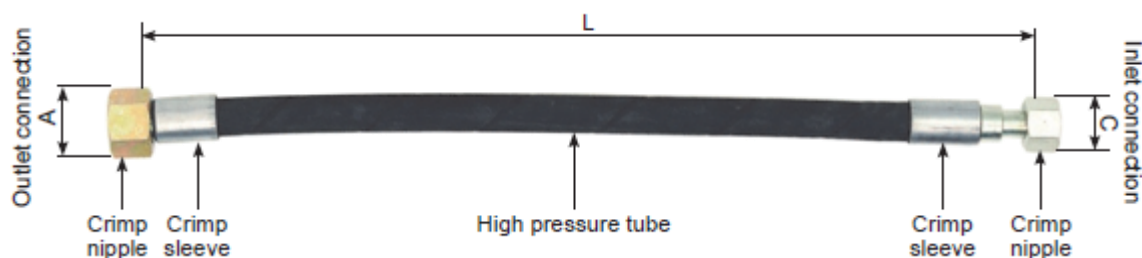

Article number	SRX 4002260	SRX 4002270
Length	400 mm	400 mm
Bending Radius	min. 130 mm	min. 180 mm
Inlet connection	W21.8 x 1/14"	
Outlet connection	G3/4"	
Nominal diameter	DN12	DN16
Working pressure	max. 380 bar	max. 350 bar
Temperature range TS	-40 °C to +100 °C	
Standard	EN 853 2 SN	
Conformity	VdS-G314019	VdS-G314020



Check valve

The check valve prevents a back-flow of the extinguishing agent into the agent container. The check valve is provided with an outlet connection thread for the connection to the manifold and an inlet connection thread for the connection to the discharge hose.

Article number	SRX 4002312
Nominal diameter	DN12
Inlet connection (c)	G3/4" ISO 228-1
Outlet connection (A)	R1" EN 10226-1
Working pressure	300 bar at 20° C
Pressure to open	< 0.1 bar
Leak rate at 20 bar	≤ 20 bubbles / 1min
Material	<ul style="list-style-type: none"> • Housing • Ball • Sealing
Conformity	VdS-G315005



Manifolds

Manifolds are used to connect several agent containers at 140 bar pressure. They can only be used with constant flow and pressure discharge regulators.

Manifolds are available in single row and double row versions for connecting 2 to 20 agent containers.

It should be manufacture from seamless steel pipes as a result of VdS hydraulic calculation. There should be welded connection ports on the main line for the constant and pressure discharge regulators to be connected to the manifold inlets.

Connection ports must be the same diameter as the pressure discharge regulator outlet connection. The end of the manifold must be closed by welding by end plug. The manifold outlet is connect to the discharge piping network.

SAFEREX System single row manifolds



Single row manifolds for 80 l. agent containers (inlet Rc 1")

Single row manifolds for 80 l. agent containers (Inlet Rc 1")			
Article number	SRX 6022732	SRX 6022733	SRX 6022735
Connection for	2 containers	3 containers	5 containers
Lenght (L)	560 mm	860 mm	1460 mm
Lenght (l)	300 mm	300 mm	300 mm
Inlet connection	Rc 1"	Rc 1"	Rc 1"
Outlet connection	R 2"	R 2"	R 2"
Working pressure	100 bar	100 bar	100 bar
Test pressure	150 bar	150 bar	150 bar
Material	Galvanised steel	Galvanised steel	Galvanised steel

Single row manifolds for 140 l. agent containers (inlet Rc 1")

Single row manifolds for 140 l. agent containers (Inlet Rc 1")			
Article number	SRX 6023562	SRX 6023563	SRX 6023565
Connection for	2 containers	3 containers	5 containers
Lenght (L)	760 mm	1160 mm	1960 mm
Lenght (l)	400 mm	400 mm	400 mm
Inlet connection	Rc 1"	Rc 1"	Rc 1"
Outlet connection	R 2"	R 2"	R 2"
Working pressure	100 bar	100 bar	100 bar
Test pressure	150 bar	150 bar	150 bar
Material	Galvanised steel	Galvanised steel	Galvanised steel

Single row manifolds for 180 l. agent containers (inlet Rc 1")

Single row manifolds for 180 l. agent containers (Inlet Rc 1")			
Article number	SRX 6024012	SRX 6024013	SRX 6024015
Connection for	2 containers	3 containers	5 containers
Lenght (L)	880 mm	1340 mm	2260 mm
Lenght (l)	460 mm	460 mm	460 mm
Inlet connection	Rc 1"	Rc 1"	Rc 1"
Outlet connection	R 2"	R 2"	R 2"
Working pressure	100 bar	100 bar	100 bar
Test pressure	150 bar	150 bar	150 bar
Material	Galvanised steel	Galvanised steel	Galvanised steel

SAFEREX System double row manifolds



Double row manifolds for 80 l. agent containers (inlet Rc 1")

Doble row manifolds for 80 l. agent containers (Inlet Rc 1")			
Article number	SRX 6022822	SRX 6022823	SRX 6022825
Connection for	2+2 4 containers	3+3 6 containers	5+5 10 containers
Lenght (L)	560 mm	860 mm	1460 mm
Lenght (l)	300 mm	300 mm	300 mm
Inlet connection	Rc 1"	Rc 1"	Rc 1"
Outlet connection	R 2"	R 2"	R 2"
Working pressure	140 bar	140 bar	140 bar
Test pressure	210 bar	210 bar	210 bar
Material	Galvanised steel	Galvanised steel	Galvanised steel

Double row manifolds for 140 l. agent containers (inlet Rc 1")

Doble row manifolds for 140 l. agent containers (Inlet Rc 1")			
Article number	SRX 6023622	SRX 6023623	SRX 6023625
Connection for	2+2 4 containers	3+3 6 containers	5+5 10 containers
Lenght (L)	760 mm	1160 mm	1960 mm
Lenght (l)	400 mm	400 mm	400 mm
Inlet connection	Rc 1"	Rc 1"	Rc 1"
Outlet connection	R 2"	R 2"	R 2"
Working pressure	140 bar	140 bar	140 bar
Test pressure	210 bar	210 bar	210 bar
Material	Galvanised steel	Galvanised steel	Galvanised steel

Double row manifolds for 180 l. agent containers (inlet Rc 1")

Doble row manifolds for 180 l. agent containers (Inlet Rc 1")			
Article number	SRX 6024122	SRX 6024123	SRX 6024125
Connection for	2+2 4 containers	3+3 6 containers	5+5 10 containers
Lenght (L)	880 mm	1340 mm	2260 mm
Lenght (l)	460 mm	460 mm	460 mm
Inlet connection	Rc 1"	Rc 1"	Rc 1"
Outlet connection	R 2"	R 2"	R 2"
Working pressure	100 bar	100 bar	100 bar
Test pressure	150 bar	150 bar	150 bar
Material	Galvanised steel	Galvanised steel	Galvanised steel

Manifold connector

The manifold connector is used to connect several manifolds.

Article number	SRX 6095001
Working pressure	140 bar
Test pressure	300 bar
Connection	2"
Material	Galvanised steel



Manifold end cap

The manifold end cap to close the end of the manifold. The red dot confirms testing up to 300 bar.

Article number	SRX 6095003
Working pressure	140 bar
Test pressure	300 bar
Connection	2"
Material	Galvanised steel



Manifold mounting rails

Part	Article number	Horizontal (L)	Vertical (L)	used for agent containers	
Manifold mounthing rail	SRX 6092731	200 mm	300 mm	single row	80 lt. containers
Manifold mounthing rail	SRX 6092732	520 mm	600 mm	double row	80 lt. containers
Manifold mounthing rail	SRX 6093561	275 mm	400 mm	single row	140 lt. containers
Manifold mounthing rail	SRX 6093562	680 mm	700 mm	double row	140 lt. containers
Manifold mounthing rail	SRX 6094101	320 mm	400 mm	single row	180 lt. containers
Manifold mounthing rail	SRX 6094102	780 mm	800 mm	double row	180 lt. containers
Clamp for manifold	SRX 6099002	2"			
End plug	SRX 1290001				



Accessories for manifolds

Pressure gauge for manifold

The pressure gauge for manifold is used to indicate the discharge pressure. It is mandatory when using directional valves (for multi-zone systems).

Article number	SRX 4002531
Inlet connection	G1/2"
Nominal diameter	80 mm
Scale	0-400 bar
Accuracy class	1,6
Liquid filling	Glycerin

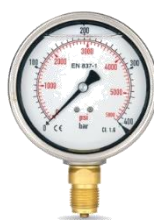

Pneumatic alarm device (for multi-zone systems)

The pneumatic alarm device is provided for system actuation warning.

Article number	SRX 4002541	SRX 4002542
Inlet connection	G1/4"	G1/4"
Sound pressure	100 ±5 db(A)	115 ±5 db(A)
Conformity	VdS-G322025	



Non-electric blocking device (for multi-zone systems)

The non-electric blocking device has to be installed for each flooding zone.

Article number	SRX 4002536
Pipe connection	G1/4"
Nominal diameter	DN6
Max. operating pressure	10 bar
Operating temperature	-20 °C to +50 °C
Conformity	VdS-G316007



Optional components

Pressure relief device for manifold

The pressure relief device for manifold is a safety device to prevent overpressure in manifolds in fire fighting systems using inert gases which are equipped with a pressure regulator operating under 60 bar.

Article number	SRX 4002532
Set pressure	66 bar at 20° C
Outlet connection (A)	G1/2"
Inlet connection (C)	G1/2"



Pressure and flow detector switch

The pressure and flow detector switch is used to monitor the pressure either in the pipework or in the pilot line and to trigger an alarm in case of actuation. An increase in pressure causes axial movement of the internal parts, which leads to switching of the electrical contacts inside the pressure and flow detector switch.

Furthermore, the pressure and flow detector switch can be actuated manually. After an actuation the pressure and flow detector switch must be reset manually.

Article number	SRX 4002521
Opening pressure	2 bar
Design pressure	200bar
Test pressure	300 bar
Inlet connection (C)	G1/2"
Operating temperature	Max. 85° C
Power source	400 V AC / 3 A or 24 V DC / 10 A
Dimensions (L x W x H)	109.9 x 105 x 47 mm
Protection class	IP65



Monitoring switch for electromagnetic release device

Article number	SRX 4001030
----------------	-------------

The monitoring switch (for electromagnetic release device) monitors if the electromagnetic release device is properly in place to actuate the system. It is connected to the control box.



Tamper device

Article number	SRX 1100695
----------------	-------------

The tamper device is a red sticker with an imprint **SAFE WARRANTY**. It is used as a seal to avoid manipulation of the electromagnetic release device after installation. It is also used to seal the control box in a multi-zone systems.

Nozzels for SAFEREX System

The 180 and 360 degree range of discharge nozzels are designed to provide the required flow rate and distribution of Inert Gases for total flooding of hazard areas. The 180° nozzle is engineered to provide a 180° discharge pattern for sidewall applications. The 360° nozzle offers a full 360° discharge pattern for installations where nozzels may be located in the centre of the hazard. The nozzle diameters should be dimensioned in accordance with the specifications of the VdS component approvals even when the system is not intended to be a VdS system.

The nozzels are made of brass and available with the inlet connections (C) R1/2", R3/4", R1" and R1 1/2".



Technical specifications and variants for SAFEREX System nozzels:

Nozzels for SAFEREX System consisting of:	
Variants	180° Nozzels sidewall applications 360° Full discharge nozzels. Located in the center of hazard.
Sizes	G 1/2" to G 1 1/2"
Working pressure	60 Bar
Operating temperature range	-20 °C to +50 °C
Technical specifications	
Body	Brass
Circlip	Stainless steel

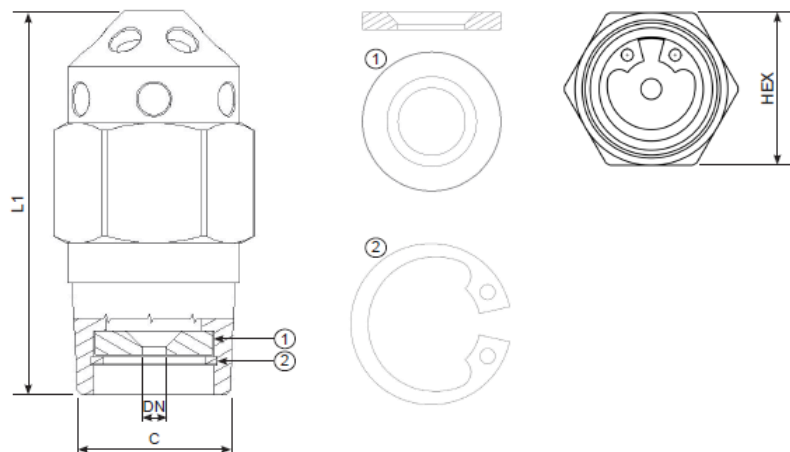

Legent			
1	Flow restrictor	DN	Orifice diameter
2	Safety clip	L1	Lenght
C	Inlet connection	HEX	Wrench size

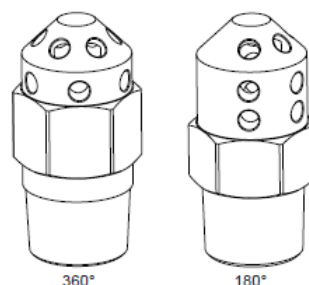

180° Sidewall nozzles

Article number	Inlet connection (C) EN 10226-1	Orifice diameter (DN) [mm]	Lenght [mm]	HEX [mm]
SRX 7418015 – XX,X	R 1/2"	3 to 10	48	22
SRX 7418020 – XX,X	R 3/4"	7 to 14	59	27
SRX 7418025 – XX,X	R 1"	10 to 18	75	36
SRX 7418040 – XX,X	R 1" 1/2	15 to 26	104	52
Conformity	VdS-G315010			



360° Nozzles

Article number	Inlet connection (C) EN 10226-1	Orifice diameter (DN) [mm]	Lenght [mm]	HEX [mm]
SRX 7436015 – XX,X	R 1/2"	3 to 10	48	22
SRX 7436020 – XX,X	R 3/4"	7 to 14	59	27
SRX 7436025 – XX,X	R 1"	10 to 18	75	36
SRX 7436040 – XX,X	R 1" 1/2	15 to 26	104	52
Conformity	VdS-G315010			



Silent discharge nozzles

The Silent Nozzles may only be used as room protection nozzle in SAFERERX systems using inert gases.

The Silent Nozzle distributes the extinguishing agent evenly in the fire suppression zone in the calculated flooding time.

The Silent Nozzle is available with different inlet connection sizes and can be screwed into any pipework that corresponds to the pressure rating and inlet connection.

The outlet of the Silent Nozzle must always face downwards in order to distribute the extinguishing agent effectively and to avoid contaminations.

Article number	Inlet connection (C) EN 10226-1	Orifice diameter (DN) [mm]	Lenght [mm]
SRX 7440015 – XX,X	R 1/2"	3 to 10	71
SRX 7440025 – XX,X	R 1"	9 to 18	151
Conformity	VdS-G319011		



- Efficient noise reduction: under 103 dBA at 1 meter
- Available 1" or 1/2"
- Homogeneous agent repartition 360° difission
- Ultra compact design

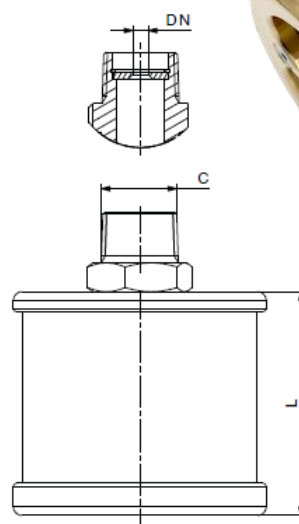
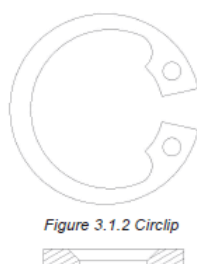

Legent			
C	Inlet connection	DN	Orifice diameter
L	Lenght		

Silent discharge nozzles where you drill your required orifice diameter and assemble yourself.

Agent container label

Agent containers are filled with the extinguishing agent at a SAFE Teknoloji San. ve Tic. Ltd. Şti. manufacturing facility and labelled with filling, safety, transport, maintenance and warning information.

Key features	Self-advise
Dimensions	235 x 175 mm

Article number	Extinguishing agent
SRX 1100621	IG01
SRX 1100622	IG100
SRX 1100623	IG55
SRX 1100624	IG541



Danger and warning signs

Danger and warning signs are provided to alert personnel that the storage room, the room or the building is protected with a SAFEREX System and that they must not enter the area during or after discharge. The danger and warning signs must be placed in a conspicuous location at the entrance to the protected space and or on the enclosure that is being protected.

Key features	Self-advise
Dimensions	200 x 150 mm



Article number: SRX 1100626



Article number: SRX 1100629

Key features	Self-advise
Dimensions	240 x 150 mm



Article number: SRX 1100627



Article number: SRX 1100628

Software availability

Design Software is available to calculate fire suppression systems to ISO 14520, VdS 2380, and NFPA 2001.

The software is easy to use and only by entering the overall project data (protected area space, type of gas, application...), the software enables users to have a precise overview of the given project thanks to:

- Calculation of the extinguishing agent's amount,
- Calculation of the equipment and components,
- Outline of the optimal installation design.

Extinguishing agent	Article number for VdS calculation software	Article number for VdS calculation software manual
IG01	SRX 1100783	SRX 1100793
IG100	SRX 1100784	SRX 1100794
IG55	SRX 1100785	SRX 1100795
IG541	SRX 1100786	SRX 1100796



Pneumatic directional valves (for multi-zone systems)

Directional valves are used in multi-zone systems.

A directional valve is used when multiple extinguishing zones are protected by the same set of agent containers. The directional valve directs the extinguishing agent to the appropriate extinguishing zone.

The directional valves are controlled pneumatically for opening.

In addition, a manual switching operation (manual override) is possible with the wrench attached at the directional valve.

Each directional valve is equipped with a monitoring device which shows position (open or closed) of the directional valve and thus provides both a visual and electrical indication of the status of the directional valve.



Article number	SRX 4005505	SRX 4005515	SRX 4005525	SRX 4005535	SRX 4005545	SRX 4005555
Diameter	G1"	G1 1/2"	G2"	G2 1/2"	G3"	G4"
Working pressure	140 bar	140 bar	140 bar	140 bar	140 bar	140 bar
Actuation pressure	6 - 10 bar	6 - 10 bar	6 - 10 bar	6 - 10 bar	6 - 10 bar	6 - 10 bar
Material	Carbon steel	Carbon steel	Carbon steel	Carbon steel	Carbon steel	Carbon steel
Conformity	VdS-G316006					

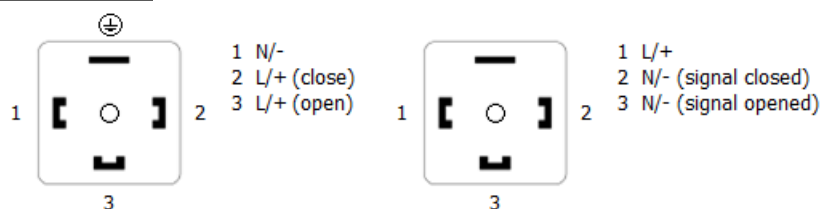

Pneumatic control panels (UL/FM)

The pneumatic control panel is intended for use in total flooding systems with inert gases.

Product repairs must only be performed by the manufacturer or with prior written consent of the manufacturer using only original spare parts.

Extinguishing agent	IG01 – IG100 – IG55 – IG541
Maximum inlet pressure	60 bar
Outlet operating pressure	8 bar
Connection therad	G1/4"
Inlet connection for pilot hose	1/4"
Operating tempetura range TS	-20 °C to +50 °C
Voltage (Volt)	24 V DC ± 10%
Protection class	IP65
Minimum actuation time	≥ 5 seconds

Article number	Number of zones	Dimensions (LxH)
SRX 4007002	2 Zones	470 x 450
SRX 4007003	3 Zones	470 x 450
SRX 4007004	4 Zones	470 x 450
SRX 4007005	5 Zones	470 x 450
SRX 4007006	6 Zones	470 x 450
SRX 4007007	7 Zones	700 x 450
SRX 4007008	8 Zones	700 x 450
SRX 4007009	9 Zones	700 x 450
SRX 4007010	10 Zones	700 x 450



- Available in multiple version from 2 to 10 zones protection.
- For UL, tamper evident seal must be used to seal the electrical control box after installation. (to be ordered seperately)



Pneumatic control panels (VdS)

The pneumatic control panel according to EN12094-2 (CE 21 0786-CPR-30238 / 30239) is intended for use in total flooding systems with inert gases.. There are 3 different types of pneumatic control panels. which are described in detail below pages.

The product is defined for the European market/countries according to European regulations and directives. For use in other countries ask for prior written agreement from SAFE Teknoloji Sanayi ve Ticaret Ltd. Şti.

- Pneumatic control with time delay device SRX 40071XX (for multi-zone systems)
- Pneumatic control without time delay device SRX 40072XX (for multi-zone systems)
- Pneumatic control with time delay device SRX 4008001 (for single-zone systems)

Extinguishing agent	IG01 – IG100 – IG55 – IG541
Minimum inlet pressure	60 bar
Maximum inlet pressure	300 bar at +50 °C
Outlet pressure	10 bar fixed
Time delay	3 to 100 seconds
Pneumatic test connection	M16 x 2 / DKOL08
Pneumatic outlet connection (A1)	Bulkhead fitting 8L
Pneumatic outlet connection (A2)	Bulkhead fitting 10L
Pneumatic inlet connection (C)	M12 x 1,5
Operating tempetura range TS	-20 °C to +50 °C
Electrical connection	PG gland (cable 3,5 – 8 mm)
Voltage (Volt)	24 V DC ± 10%
Wattage (Watt)	3 W
Protection class	IP65
Minimumactuation time	≥ 5 seconds
Weight	Max. 18 kg (depending on variant)
Conformity	VdS-G321004



Pneumatic control panel with time delay device (SRX 40071XX)

The pneumatic (non-electric) control panel with time delay device (SRX 40071XX) is used to actuate directional valves in multi-zone systems in the event of fire, with which individual hazard areas are released for flooding. The actuation is made with control valves. Control valves are electro-pneumatic valves. The pneumatic supply is provided by a separate pilot cylinder.

There is also the option of delayed actuation of reserve agent containers. The switchover to the reserve agent containers is provided by an integrated switching device, whose position can be monitored (main/reserve).

In addition, it is also possible to connect a pneumatic alarm device to the pneumatic control and delay device for each hazard area.

Article number	Number of zones	Number of Extinguishing groups	Height (mm)	Width (mm)	Depth (mm)	Conformity
SRX 4007102	2 Zones	2	1000	800	300	VdS-G321004
SRX 4007103	3 Zones	3	1000	800	300	VdS-G321004
SRX 4007104	4 Zones	4	1000	800	300	VdS-G321004
SRX 4007105	5 Zones	5	1000	800	300	VdS-G321004
SRX 4007112	2 Zones	2	800	800	300	VdS-G321004
SRX 4007113	3 Zones	3	800	800	300	VdS-G321004
SRX 4007114	4 Zones	4	800	800	300	VdS-G321004
SRX 4007115	5 Zones	5	800	800	300	VdS-G321004



* 1 x directional valve + max. quantity of extinguishing groups

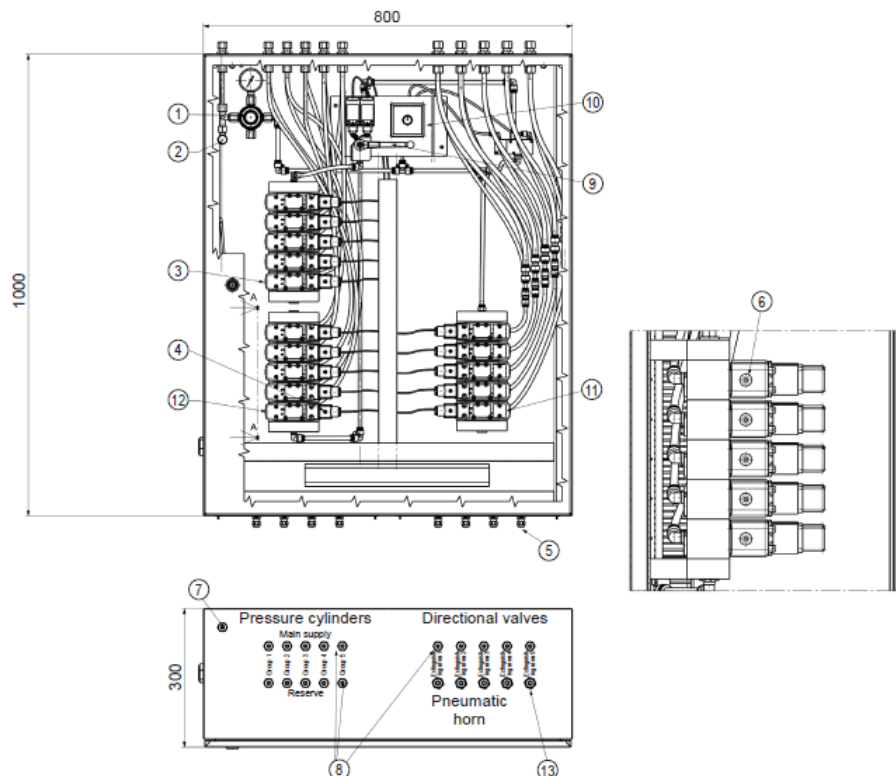

Legent

1	Pressure regulator	8	Pneumatic outlet connection (A1)
2	Pneumatic test connection	9	Switching device
3	Control valve agent container	10	Timer
4	Manual actuation	11	Control valve extinguishing zone 1 – 5
5	PG cable gland	12	Control valve reserve agent container
6	Manual reset	13	Pneumatic outlet connection (A2)
7	Pneumatic inlet connection		

Pneumatic control panel without time delay device (SRX 40072XX)

The pneumatic (non-electric) control panel (SRX 40072XX) is used to actuate directional valves in multi-zone systems in the event of fire, with which individual hazard areas are released for flooding. The actuation is made with control valves. Control valves are electro-pneumatic valves. The pneumatic supply is provided by a separate pilot cylinder.

There is also the option of delayed actuation of reserve agent containers. The switchover to the reserve agent containers is provided by an integrated switching device, whose position can be monitored (main/reserve).

Article number	Number of zones	Number of Extinguishing groups	Height (mm)	Width (mm)	Depth (mm)	Conformity
SRX 4007202	2 Zones	2	1000	800	300	VdS-G321004
SRX 4007203	3 Zones	3	1000	800	300	VdS-G321004
SRX 4007204	4 Zones	4	1000	800	300	VdS-G321004
SRX 4007205	5 Zones	5	1000	800	300	VdS-G321004
SRX 4007212	2 Zones	2	800	800	300	VdS-G321004
SRX 4007213	3 Zones	3	800	800	300	VdS-G321004
SRX 4007214	4 Zones	4	800	800 <td 300	VdS-G321004	
SRX 4007215	5 Zones	5	800	800	300	VdS-G321004



* 1 x directional valve + max. quantity of extinguishing groups

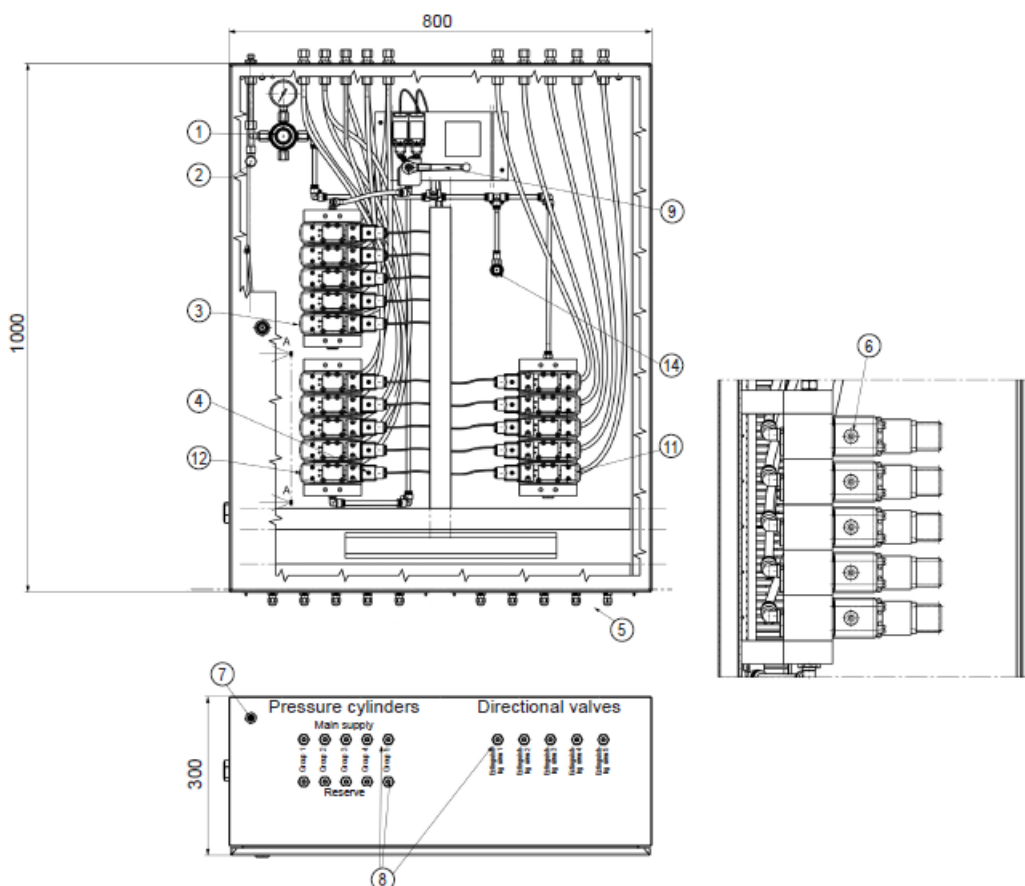

Legent

1	Pressure regulator	7	Pneumatic inlet connection
2	Pneumatic test connection	8	Pneumatic outlet connection (A1)
3	Control valve agent container	9	Switching device
4	Manual actuation	11	Control valve extinguishing zone 1 – 5
5	PG cable gland	12	Control valve reserve agent container
6	Manual reset	14	Bleed valve

Pneumatic control panel with time delay device (SRX 4008001) for single-zone systems

In the event of a fire in a single-zone system, the pneumatic control and time delay device (SRX 4008001) is used to actuate the agent containers filled with extinguishing agent with a delay. The actuation is made with control valves. Control valves are electro-pneumatic valves. The pneumatic supply is provided by a separate pilot cylinder.

In addition, it is possible to connect a pneumatic alarm device to the pneumatic control panel and time delay device. A non-electric blocking device is integrated to block the actuation of the agent containers.

Article number	Number of zones	Number of Extinguishing groups	Height (mm)	Width (mm)	Depth (mm)	Conformity
SRX 4008001	1 Zones	1	500	400	200	VdS-G321004

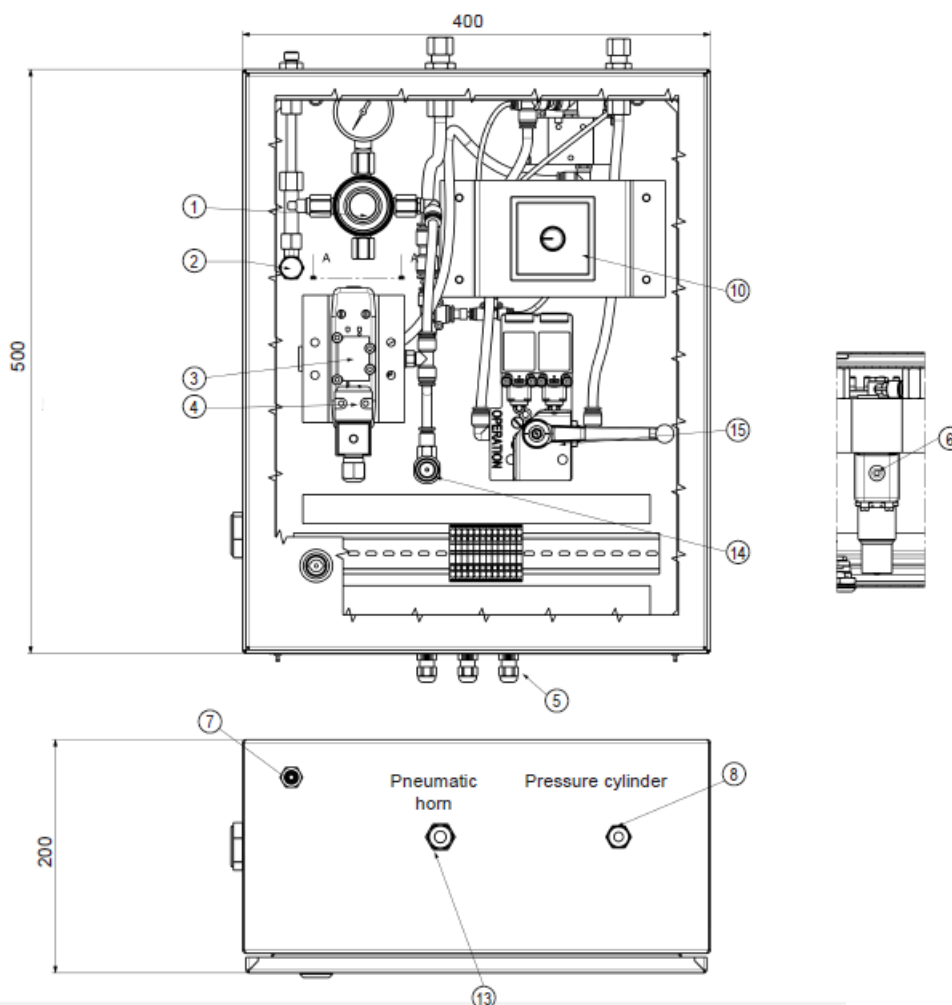

Legent

1	Pressure regulator	7	Pneumatic inlet connection
2	Pneumatic test connection	8	Pneumatic outlet connection (A1)
3	Control valve agent container	10	Timer
4	Manual actuation	13	Pneumatic outlet connection (A2)
5	PG cable gland	14	Bleed valve
6	Manual reset	15	Non-electric blocking device

SAFE TEKNOLOJİ SAN. VE TİC. LTD. ŞTİ.
MOSB IV. Kısım İsmail Kahraman Cad. No.3
45030 Manisa Türkiye

Tel: +90 (236) 236 3360
Fax: +90 (236) 236 3365
Email: info@safe-tr.com
<http://safe-tr.com>

Article nr. SRX 1100765 - Revision A_R
Effective November 10th 2023

© This document is an intellectual property of SAFE Teknoloji Sanayi ve Ticaret Ltd. Şti.
and it cannot be neither copied nor reproduced or transmitted to third parties without the written consent of